

# TesiMod Operating Terminal BT20N Standard with Brackets BT20N Standard with Bolts BT20N Field Bus with Brackets BT20N Field Bus with Bolts



## INSTRUCTION SHEET

Thank you for purchasing this SÜTRON product. Please read this instruction sheet and thoroughly familiarize yourself with the functions and characteristics of the product before use. Please retain this sheet for future reference.

For more information on specifications and usage, please refer to the technical manual of the operating terminals.



SÜTRON ELECTRONIC GmbH

All Rights Reserved

BT20N\_IS\_eng\_V10.3200000QK0

## Notice

- When unpacking the unit, check carefully for any external scratches or other damage. Also, shake the unit gently and check for any abnormal sound.
- Do not touch PCBs with bare hands. Discharge static electricity accumulated in your body in advance.
- The mounting panel must be between 1.0 and 10.0 mm thick. Tighten the nuts, respectively the mounting brackets, evenly to maintain water and dust resistance. Make sure the panel is not dirty or warped and that it is strong enough to hold the unit.
- Do not let metal particles enter the unit when preparing the panel.
- Double-check all the wiring before turning ON the power supply.
- Do not connect an AC power supply to the DC power supply terminals.
- Do not perform a dielectric voltage test.
- Use a DC power supply according to the following specifications: SELV according to EN 61131  
24 V Direct Voltage, Residual Ripple Max. 10%  
Minimum Voltage ..... 19.2 V  
Maximum Voltage ..... 30.2 V  
Typ. Power Consumption ..... 0.7 A  
Peak Current (10 ms) ..... 3.0 A  
Capacity ..... 20 W min.
- Use twisted-pair cable of at least 2 mm<sup>2</sup> to connect to the power supply terminals. Use the connector type Phoenix COMBICON MSTB 2.5/3-STF to plug on the supply voltage.
- Turn OFF the power supply to the unit before connecting or disconnecting cables between devices.
- Always tighten the connector screws after connecting power supply and / or communication cables.
- Start actual system application only after sufficiently checking the application program.
- Do not attempt to disassemble, repair, or modify the unit in any way.
- To assure system safety, incorporate a routine that periodically checks the liveness flag of the poll area to check that the unit is properly operating.
- Dispose of the unit and batteries according to local ordinances as they apply.
- Do not install the unit in any of the following locations.
  - Locations subject to rapid changes in temperature.
  - Locations subject to temperatures or humidities outside the range specified in the technical data.
  - Locations subject to condensation as the result of high humidity.
  - Locations subject to splashing chemicals or solvents.
  - Locations subject to oil splashes.
  - Locations subject to corrosive or flammable gases.
  - Locations subject to strong shock or vibration.
  - Locations outdoor subject to direct wind and rain.
  - Locations subject to strong ultraviolet light.
- Take appropriate and sufficient countermeasures when installing systems in the following locations.
  - Locations subject to static electricity or other forms of noise.
  - Locations subject to strong electromagnetic or magnetic fields.
  - Locations close to power supply lines.
  - Locations subject to possible exposure to radioactivity.
- An afterimage will remain if the same patterns are displayed continuously for extended periods of time (e.g., 24 hours). Use the screen saver or periodically change the display to prevent afterimages.
- Do not use benzene, paint thinner, or other volatile solvents, and do not use chemical treated cloths.

## Checking of Accessories

Confirm that the unit is supplied with the following parts.

- Connector for the supply voltage - Phoenix COMBICON MSTB 2.5/3-STF
- Set of slide-in identification strips
- Four mounting brackets

## Connector Pin Arrangement

### Connector for Communication/Download/Upload/Printer/Scanner Standard Unit

25-pin SubminD Female Connector

Pin	Designation	Channel	Type	Description
1	Shield	SER2	RS232c	Shield Connection
2	TD	SER2	RS232c	Transmit Data
3	RD	SER2	RS232c	Receive Data
4	RTS	SER2	RS232c	Request To Send
5	CTS	SER2	RS232c	Clear To Send
6	TD	SER1	RS232c	Transmit Data
7	SGND	SER2	RS232c	Signal Ground
8	T(A)	SER1	RS485	Transmit Data Channel A
9	T(B)	SER1	RS485	Transmit Data Channel B
10	T+	SER1	TTY	Transmit Data, Positive Polarity
11	SGND	SER1	RS485	Signal Ground
12	S1+	SER1	TTY	Power Source 1, Positive Polarity
13	R+	SER1	TTY	Receive Data, Positive Polarity
14	R-	SER1	TTY	Receive Data, Negative Polarity
15	CTS	SER1	RS232c	Clear To Send
16	S2+	SER1	TTY	Power Source 2, Positive Polarity
17	RTS	SER1	RS232c	Request To Send
18	RD	SER1	RS232c	Receive Data
19	T-	SER1	TTY	Transmit Data, Negative Polarity
20	DTR	SER2	RS232c	Data Terminal Ready
21	S1-	SER1	TTY	Power Sink 1, Negative Polarity
22	R(A)	SER1	RS485	Receive Data Channel A
23	R(B)	SER1	RS485	Receive Data Channel B
24	S2-	SER1	TTY	Power Sink 2, Negative Polarity
25	SGND	SER1	RS232c	Signal Ground

Connect the cable shield to the metal hoods of the connectors over as large a surface as possible!

### Connector for Download/Upload/Printer/Scanner Field Bus Unit

25-pin SubminD Female Connector

Pin	Designation	Channel	Type	Description
1	Shield	SER2	RS232c	Shield Connection
2	TD	SER2	RS232c	Transmit Data
3	RD	SER2	RS232c	Receive Data
4	RTS	SER2	RS232c	Request To Send
5	CTS	SER2	RS232c	Clear To Send
6	nc	SER1	-	Not Connected
7	SGND	SER2	RS232c	Signal Ground
8	nc	SER1	-	Not Connected
9	nc	SER1	-	Not Connected
10	nc	SER1	-	Not Connected
11	nc	SER1	-	Not Connected
12	nc	SER1	-	Not Connected
13	nc	SER1	-	Not Connected
14	nc	SER1	-	Not Connected
15	nc	SER1	-	Not Connected
16	nc	SER1	-	Not Connected
17	nc	SER1	-	Not Connected
18	nc	SER1	-	Not Connected
19	nc	SER1	-	Not Connected
20	DTR	SER2	RS232c	Data Terminal Ready
21	nc	SER1	-	Not Connected
22	nc	SER1	-	Not Connected
23	nc	SER1	-	Not Connected
24	nc	SER1	-	Not Connected
25	nc	SER1	-	Not Connected

Connect the cable shield to the metal hoods of the connectors over as large a surface as possible!

## Connector for Power Supply

The unit is equipped with a reverse voltage protection. If the poling is wrong, the unit doesn't operate.

This unit confirms to the safety class I. For safe operation it is necessary to use safety extra-low voltage (SELV) in accordance with DIN EN 61131 for the supply voltage.

3-pin Male Connector Phoenix COMBICON MSTBV 2,5/3-GF

Pin	Designation	Description
1	Ⓧ	Signal Ground (Functional Ground)
2	0 V	Supply Voltage 0 V
3	24 VDC	Supply Voltage 24 VDC

## Grounding



Separate ground screw for protective grounding

A separate ground conductor must be provided for the ground screw in each case. The minimum cross-section of the ground conductor must be 1.5 mm<sup>2</sup>. Compliance with this information increases the operational safety.

## Setup of Operating Mode

### User-Mode Switch

The user-mode switch is placed at the rear side of the unit. The switch levers can be accessed by using a pen or a small screwdriver.



S1	S2	S3	S4	S5	S6	S7	S8	Function
I	X	-	-	X	X	X	X	Standard-Mode with PLC (delivery state)
I	X	I	-	X	X	X	X	Standard-Mode without PLC
-	I	-	-	X	X	X	X	Transparent-Mode with start and stop code of the keys
-	-	-	I	X	X	X	X	Transparent-Mode without stop code of the keys
I	-	-	I	X	X	X	X	Activate download (deletes application memory) und default contrast setting

Legend of above table:

- I = Switch position ON
- = Switch position OFF
- X = Switch position irrelevant

## Shielding of SubminD - Interconnections

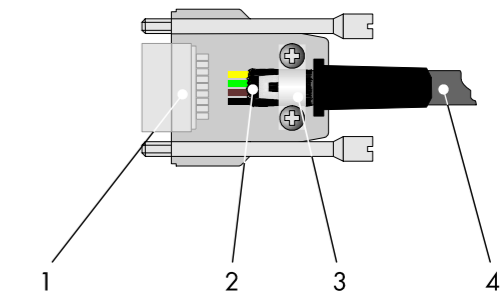

- 1 SubminD Connector
- 2 Shield
- 3 Cord Grip
- 4 Cable

The shield must be pushed back tubularly.

By fastening the cable with the cord grip you have to ensure an electrical contact of the shield to the housing over an area as wide as possible and an appropriate strain relief.

## Safety Precautions

### Definition of Precautionary Information

**DANGER** Indicates an imminently hazardous situation which, if not avoided, will result in death or serious injury.

**WARNING** Indicates a potentially hazardous situation which, if not avoided, could result in death or serious injury.

**CAUTION** Indicates a potentially hazardous situation which, if not avoided, may result in minor or moderate injury, or property damage.

### Warnings

**WARNING** Do not attempt to take the unit apart and do not touch any internal parts while the power is being supplied. Doing either of these may result in electric shock.

**WARNING** Switch OFF the power of the unit before replacing the enclosure. Otherwise you could sustain an electric shock.

**CAUTION** Electrostatic discharges can damage electronic components! ESD protective measures must be observed.

## External Dimensions

### Front View with Brackets

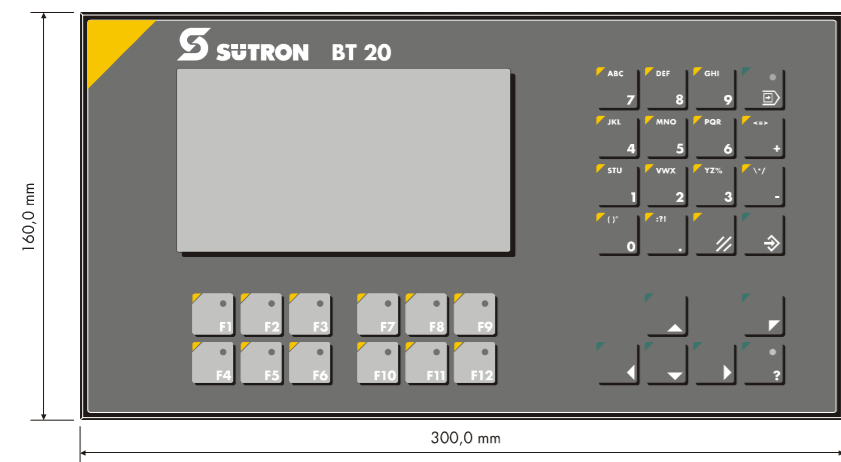

### Front View with Bolts



### Side View with Brackets

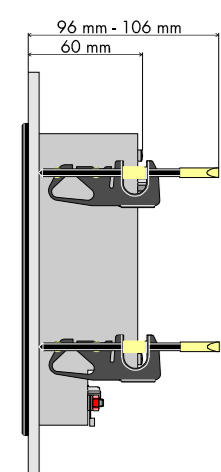

### Side View with Bolts

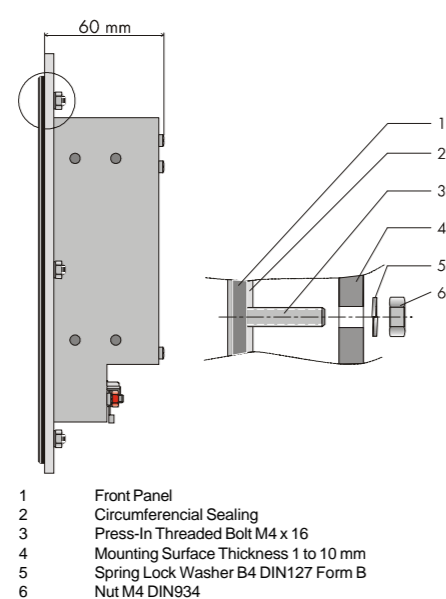

**TOP** ←

