

User Manual

Connection to Moeller SUCOM1 PS4-201

Part Number: 80 860.679
Version: 2
Date: 30.05.2006
Valid for: TSwin .net 4.1x

Version	Date	Modifications
1	17.11.2005	First edition
2	30.05.2006	New Layout, protocol name modified

This manual, including all illustrations contained herein, is copyright protected. Use of this manual by any third party in departure from the copyright provision is forbidden. No part of this manual may be reproduced, translated or electronically or photographically archived or altered without the express written consent from Süttron electronic GmbH. Violations shall be cause for damage liability.

Süttron electronic reserves the right to make any changes that contribute to technical improvement.

Overall Table of Contents

1	Important Notes	1-1
	1.1 Symbols	1-1
	1.2 Safety Notes	1-1
	1.3 Intended Use.....	1-1
	1.4 Target Group.....	1-1
2	Moeller SUCOM1 PS4-201.....	2-1
	2.1 Data Types.....	2-1
	2.2 Programming	2-1
	2.2.1 Protocol Parameters	2-1
	2.2.1.1 Baud Rate	2-1
	2.2.1.2 Parity.....	2-2
	2.2.1.3 Handshake.....	2-2
	2.2.1.4 Data Bits	2-2
	2.2.1.5 Stop Bits	2-3
	2.2.1.6 Swap LED Output	2-3
	2.2.2 Input Syntax.....	2-3
	2.2.3 Physical Connection	2-4
	2.2.3.1 Pin Assignment for Operating Devices with an Universal Interface.....	2-4
	2.2.3.2 Cable SER1 RS232 - Moeller PS4-201	2-4
	2.3 Error Messages.....	2-5
A	Index.....	A-1

1 Important Notes

1.1 Symbols

The symbols in this manual are used to draw your attention on notes and dangers.



Danger

This symbol is used to refer to instructions which, if ignored or not carefully followed could result in personal injury.



Note

This symbol indicates application tips or supplementary notes.



Reference to source of information

This symbol refers to detailed sources of information on the current topic.

1.2 Safety Notes

- Read this manual carefully before using the software. Keep this manual in a place where it is always accessible to all users.
- Proper handling of this product is a prerequisite for its subsequent flawless and safe operation.
- The user manual, in particular the safety notes, must be observed by all personnel working with the software and the programmed device.
- Observe the accident prevention rules and regulations that apply to the operating site.
- Installation and operation must only be carried out by qualified and trained personnel.

1.3 Intended Use

- The software has to be used for programming operating devices exclusively. Every other use is not permitted.

1.4 Target Group

All configuration and programming work in connection with the automation system must be performed by trained personnel only (e.g. qualified electricians, electrical engineers).

The configuration and programming personnel must be familiar with the safety concepts of automation technology.

2 Moeller SUCOM1 PS4-201

The Moeller SUCOM1 PS4-201 protocol provides you

- random read and write access to all flags of the controller
- bit access to all flag types

The size of the address area depends on the controller being used.



Before individual bits can be accessed for a write operation, a read access to the addressed word is performed. Then the write access to the bit can be carried out. For this type of access, you must therefore ensure that the operating device and the controller do not modify individual bits of the same word.

2.1 Data Types

Direct access is possible to the following data types.

Table 2-1 Moeller SUCOM1 PS4-201 data types

Type	Mnemonic	Access
Flag Bit	M	Bit Access
Flag Byte	MB	Byte Access
Flag Word	MW	Word Access
Process Status Word	PS	Word Access
Diagnostics Word	DS	Word Access
Diagnostics Counter	DZ	Word Access (Read Only)

2.2 Programming

2.2.1 Protocol Parameters

With the protocol parameters, you can adapt the communication of the controller used.

2.2.1.1 Baud Rate

This parameter specifies the communication rate.

Table 2-2 Baud rate

Configurable Values (Baud)	Default value
300	
600	
1200	
2400	

Table 2-2 Baud rate

Configurable Values (Baud)	Default value
4800	
9600	X
19200	
38400	
57600	
76800	
115200	

2.2.1.2 Parity

This parameter specifies the parity used to control the communication.

Table 2-3 Parity

Configurable Values	Default Value
None	X
Even	
Odd	

2.2.1.3 Handshake

This parameter specifies the method used to control the communication.

Table 2-4 Handshake

Configurable values	Default Value
No Handshake	X
Hardware	
Software	

2.2.1.4 Data Bits

This parameter specifies the number of data bits.

Table 2-5 Data bits

Configurable Values	Default Value
5	
6	
7	
8	X

2.2.1.5 Stop Bits

This parameter specifies the number of stop bits.

Table 2-6 Stop bits

Configurable Values	Default Value
1	
1.5	
2	X

2.2.1.6 Swap LED Output

This parameter specifies whether the bytes responsible for controlling the LEDs in the polling area are to be swapped (byte swapping).

Table 2-7 Swap LED output

Configurable Values	Default Value
ON	
OFF	X

2.2.2 Input Syntax

The following image illustrates the structure of the input syntax for variables in the programming software.

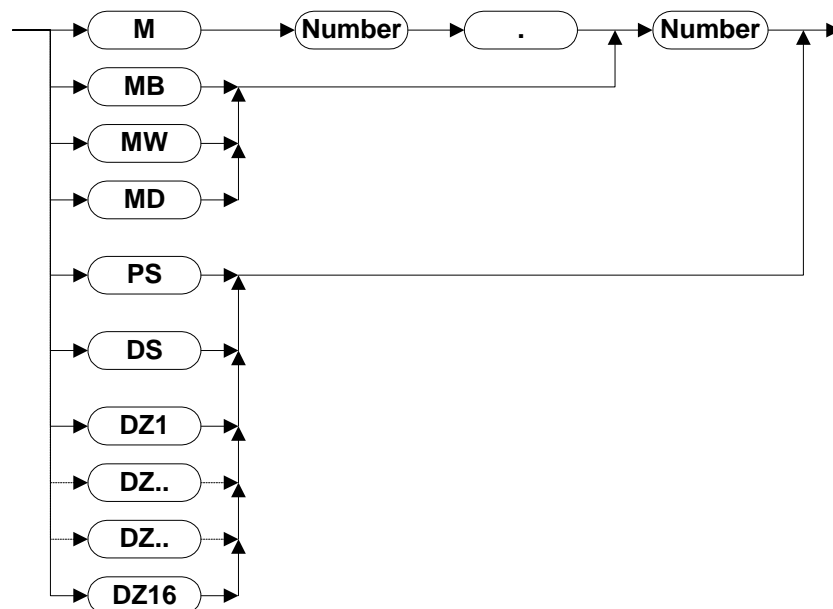

Figure 2-1 Syntax diagram, Moeller SUCOM1 PS4-201

2.2.3 Physical Connection

Plug-in connectors on the operating device for connection to the controller.

2.2.3.1 Pin Assignment for Operating Devices with an Universal Interface

Table 2-8 Pin assignment RS232

Pin	Designation	Function
6	TD	Transmitted Data
15	CTS	Clear to send
17	RTS	Request to send
18	RD	Received data
25	SGND	Signal Ground

2.2.3.2 Cable SER1 RS232 - Moeller PS4-201

The following cabling diagram applies to operating devices with an universal interface **only**.

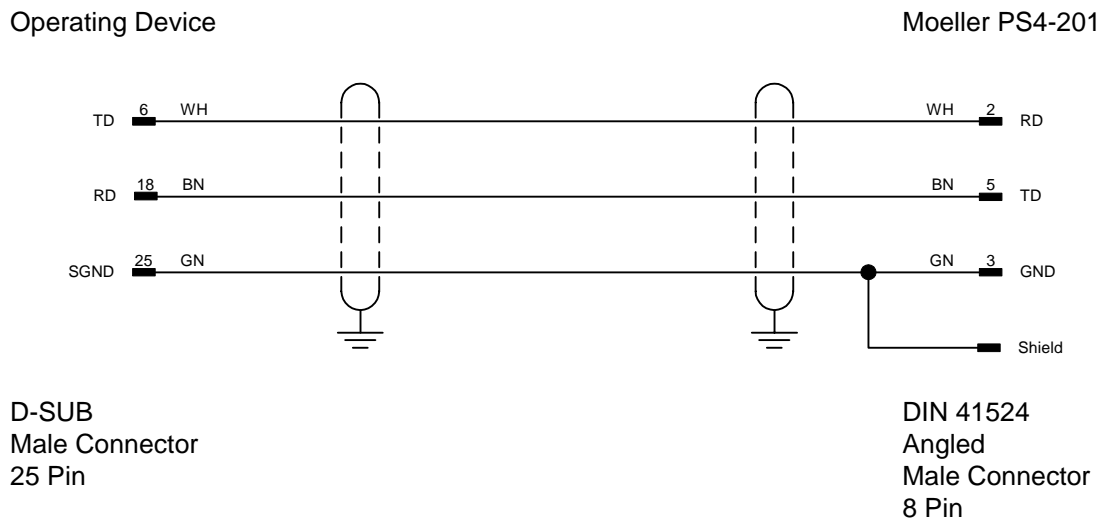

Both ends of the shield are connected to the metallic housing.

2.3 Error Messages

Error messages are displayed on the operating device along with a code and sub-code. Error messages are composed as follows:

Communication Error
 Code XXXXX
 Subcode XXXXX
 Retries XXXXX

Table 2-9 Moeller SUCOM1 PS4-201 error messages

Code	Subcode	Error Type	Possible Cause
1		Slave not ready	Wrong slave address or connecting cable not plugged-in properly
2		Packets out of sequence	
3		Protocol framing error	
4		Waiting time elapsed (Timeout)	Connection broken.
5		CRC error	
6		Wrong parity	
7		Send process aborted	
8		Receive process aborted	
9		Cyclic buffer overrun	Cyclic buffer too small
10		No cyclic data defined	
12		Cyclic data already defined	
15		Protocol error	The selected protocol is not supported.
16		Receive buffer overrun	
17		NAK from controller	
40		System variable error	Undefined system variable
SUCOM1-specific error messages			
50		Wrong acknowledgment during connection setup	
51		No acknowledgment after data transmission	
52		No response telegram	
53		Incorrect number of data received	Check if the mask, in which the error occurred, contains a variable with an odd number of bytes which accesses a word address or a double-word address.
54		No STX upon receipt of data block	

A Index

C

Cable SER1 RS232	
Moeller PS4-201	2-4

I

Important notes	1-1
Intended use	1-1

M

Moeller SUCOM1 PS4-201	2-1
------------------------------	-----

P

Protocol parameters	
Moeller SUCOM1 PS4-201	2-1

S

Safety notes	1-1
Symbols	1-1
Syntax diagram	
Moeller SUCOM1 PS4-201	2-3

T

Target group	1-1
--------------------	-----



