

User Manual

Connection to Siemens S5 PU (AS511)

Part Number: 80860.699
Version: 2
Date: 18.10.2006
Valid for: User Manuals

Version	Date	Modifications
1	09.06.2006	First Edition
2	18.10.2006	Optimized data transmission added, protocol parameter stop bits changed

This manual, including all illustrations contained herein, is copyright protected. Use of this manual by any third party in departure from the copyright provision is forbidden. No part of this manual may be reproduced, translated or electronically or photographically archived or altered without the express written consent from Süttron electronic GmbH. Violations shall be cause for damage liability.

Süttron electronic reserves the right to make any changes that contribute to technical improvement.

Overall Table of Contents

1	Important Notes	1-1
	1.1 Symbols	1-1
	1.2 Safety Notes	1-1
	1.3 Intended Use.....	1-1
	1.4 Target Group.....	1-1
2	Siemens S5 PU (AS511)	2-1
	2.1 Data Types.....	2-2
	2.2 Optimized Data Transmission For Fast Screen Set-up	2-3
	2.3 Programming	2-4
	2.3.1 Protocol parameters	2-4
	2.3.1.1 Baud Rate	2-4
	2.3.1.2 Parity.....	2-4
	2.3.1.3 Handshake.....	2-4
	2.3.1.4 Data Bits	2-5
	2.3.1.5 Stop Bits	2-5
	2.3.1.6 Maximum Waiting Time For Response.....	2-5
	2.3.1.7 Delay until Connection Set-Up.....	2-6
	2.3.1.8 Fast Data Block Access	2-6
	2.3.2 Input Syntax.....	2-7
	2.4 Physical Connection	2-8
	2.4.1 Pin Assignment for Operating Devices with an Universal Interface.....	2-8
	2.4.2 Cable SER1 TTY / 20 mA - Siemens S5 PU	2-9
	2.5 Error Messages.....	2-10
A	Index	A-1

1 Important Notes

1.1 Symbols

The symbols in this manual are used to draw your attention on notes and dangers.



Danger

This symbol is used to refer to instructions which, if ignored or not carefully followed could result in personal injury.



Note

This symbol indicates application tips or supplementary notes.



Reference to source of information

This symbol refers to detailed sources of information on the current topic.

1.2 Safety Notes

- Read this manual carefully before using the software. Keep this manual in a place where it is always accessible to all users.
- The user manual, in particular the safety notes, must be observed by all personnel working with the software and the programmed device.
- Observe the accident prevention rules and regulations that apply to the operating site.
- Installation and operation must only be carried out by qualified and trained personnel.

1.3 Intended Use

- The software has to be used for programming operating devices exclusively. Every other use is not permitted.

1.4 Target Group

All configuration and programming work in connection with the automation system must be performed by trained personnel only (e.g. qualified electricians, electrical engineers).

The configuration and programming personnel must be familiar with the safety concepts of automation technology.

2 Siemens S5 PU (AS511)

The Siemens S5 PU (AS511) protocol provides you

- random read and write access to all controller data
- bit access to all byte-oriented data types
- byte access to all data words in a data block.



When the system writes to individual bits and individual bytes of a data word within a data block, a read-access is performed first. Then, the entire data structure can be accessed for a write operation. During this type of access, you must take care that neither the operating device nor the controller modify individual bits in a byte (or individual bytes in a data word).

The size of the address area depends on the controller being used.

This protocol supports a connection to the following Simatic S5 types.

Table 2-1 Supported Simatic S5 types

Controller Type	CPU
SIMATIC S5-90U	8-Bit CPU
SIMATIC S5-95U	8-Bit CPU
SIMATIC S5-100U	CPU100 / 8-Bit CPU
	CPU102 / 8-Bit CPU
	CPU103 / 8-Bit CPU
SIMATIC S5-115U	CPU941 / 8-Bit CPU
	CPU942 / 8-Bit CPU
	CPU943 / 8-Bit CPU
	CPU944 / 8-Bit CPU
	CPU945 / 8-Bit CPU with 20-Bit Address Area
SIMATIC S5-135U	CPU922 / 16-Bit CPU
	CPU928 / 16-Bit CPU
	CPU928B / 16-Bit CPU
SIMATIC S5-155U	CPU948 / 20-Bit CPU

The following Simatic S5 types are **not** supported by this protocol.

Table 2-2 Simatic S5 types not supported

Controller Type	CPU
SIMATIC S5-135U	CPU921 / 16-Bit CPU

2.1 Data Types

Direct access is possible to the following data types.

The size of the individual data areas depends on the controller's CPU.

Table 2-3 Data types for Siemens S5 PG (AS511)

Type	Mnemonic	Access
Input Bit	E	Bit Access (Read-only)
Input Byte	EB	Byte Access (Read-only)
Input Word	EW	Word Access (Read-only)
Input Double-Word	ED	Double-Word Access (Read-only)
Output Bit	A	Bit Access
Output Byte	AB	Byte Access
Output Word	AW	Word Access
Output Double-Word	AD	Double-Word Access
Flag Bit	M	Bit Access
Flag Byte	MB	Byte Access
Flag Word	MW	Word Access
Flag Double-Word	MD	Double-Word Access
Data Word	DW	Word Access
Data-Word Left (High)	DL	Word Access
Data-Word Right (Low)	DR	Word Access
Data Double-Word	DD	Double-Word Access
Timer	T	Word Access (Read-only)
Counter	Z	Word Access (Read-only)

Counter:

For counters, a distinction is made between variables which have been assigned a counter address and variables which have been assigned another controller address.

When accessing counter addresses, the counter value is interpreted in binary format and the control bits of the counter are masked out.



To avoid control bits from being erased, accesses to counter addresses should be **read-only**.

The counter value is interpreted in BCD-code. This allows this value to be transferred within the controller program to the counter by means of the accumulator. Since the values are available in a Siemens compliant format, this service should be used to indirectly write counter starting values.

Timer:

Timer values are made up of a time value and a time base.

The operating device reads the 2-byte sized variable and converts it internally into an imaginary, unsigned 4-byte variable that represents the time value for the base 0.01 seconds. The operating device makes a distinction between accesses to a timer address and accesses to other controller addresses.

When accessing timer addresses, the operating device interprets the time value in binary format. When accessing another controller address, the operating device interprets the time value in BCD code.



To avoid control bits from being erased, accesses to timer addresses should be **read-only**.

Accesses to other addresses should be used to indirectly write timer starting values, since the values are provided in the Siemens compliant format.

Before the operating device writes a timer value to the controller, it converts the unsigned 4-byte variable back into a 2-byte variable with a time value for the smallest possible time base. In addition, the operating device makes a distinction between writing the timer value to a timer address and writing it to another controller address.

2.2 Optimized Data Transmission For Fast Screen Set-up

To speed-up the screen set-up on the operating devices you have to assign the variable addresses almost **consecutively** to one data area (i.e. data base) **for each screen**. Due to this optimized access the data is transmitted as a data block and therefore reduces the amount of communication telegrams. The maximum number of data that is packed to a block depends on the selected communication protocol.

Not optimized data access for **one** screen:

- access to many several data areas,
- access to scattered addresses within one data area.

Optimal data access for **one** screen:

- access to one data area,
- access to consecutive addresses within one data area.

2.3 Programming

2.3.1 Protocol parameters

With the protocol parameters, you can adapt the communication of the controller used.

2.3.1.1 Baud Rate

This parameter specifies the communication rate.

Table 2-4 Baud rate

Configurable Values (Baud)	Default value
300	
600	
1200	
2400	
4800	
9600	X
19200	
38400	
57600	
76800	
115200	

2.3.1.2 Parity

This parameter specifies the parity used to control the communication.

Table 2-5 Parity

Configurable Values	Default Value
None	
Even	X
Odd	

2.3.1.3 Handshake

This parameter specifies the method used to control the communication.

Table 2-6 Handshake

Configurable values	Default Value
No Handshake	X
Hardware	
Software	

2.3.1.4 Data Bits

This parameter specifies the number of data bits.

Table 2-7 Data bits

Configurable Values	Default Value
5	
6	
7	
8	X

2.3.1.5 Stop Bits

This parameter specifies the number of stop bits.

Table 2-8 Stop bits

Configurable Values	Default Value
1	X
1.5	
2	

2.3.1.6 Maximum Waiting Time For Response

This parameter specifies how long the operating device waits for a response from the controller.

Table 2-9 Maximum waiting time for response

Configurable Values	Default Value
50 ms to 65535 ms	1000 ms



CPUs equipped with 2 PG interfaces (e.g. CPU928B with PG module) are used during system commissioning thus keeping the PG interface available for program debugging.

Please note that the interfaces are interacting (see Siemens CPU manual). For example, if a PLC program is analyzed by means of the STATUS-function on the first interface of the CPU, this will cause the speed of protocol handling on the second interface to decrease significantly. With the STATUS-function, you can, so to speak, operate the PLC program in single-step-mode, i.e. the result of every program line is displayed on the screen.

In order to maintain the connection, you need to increase the "maximum waiting time for response" to about 5 seconds. If the normal time-out period is used, the operating terminal will generate a communication error message.

In this case each transmission requires 3-4 seconds, in contrast to a normal communication cycle which requires approximately 60ms. This means a slow-down of the interface by a factor of 50!

2.3.1.7 Delay until Connection Set-Up

This parameter specifies the waiting time after which the operating device starts the communication.

Table 2-10 Delay until connection set-up

Configurable Values	Default Value
0 s to 20 s	2 s

2.3.1.8 Fast Data Block Access

This parameter specifies whether a fast data block access is used.

Table 2-11 Fast data block access

Configurable Values	Default Value
ON	
OFF	X



The following applies to the fast data block access:
 The base address for each data block being used is determined only once and this information is stored temporarily in a local buffer with 10 positions. Any subsequent accesses continue to operate with the information stored in the local buffer. The information in the buffer is erased when the operating device is rebooted or when a resynchronization is carried out after a communication error has occurred. In this case, do not modify data blocks dynamically or compress the memory while the connection between the operating device and the controller is still active!



The following applies if an operating device and a programming unit are simultaneously connected to the controller by means of a multiplexer: the address location of the data blocks changes whenever you change the values of a data block using the programming device and transfer the data block to the controller again.

2.3.2 Input Syntax

The following image illustrates the structure of the input syntax for variables in the programming software.

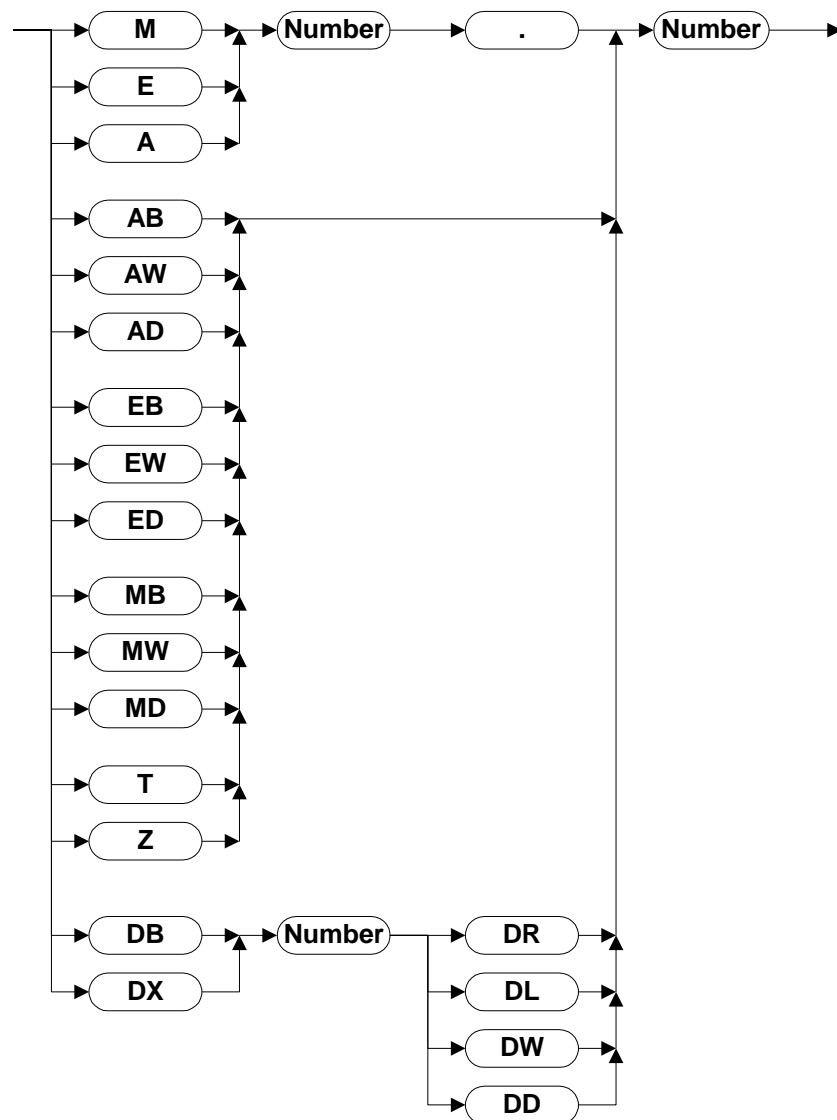

Figure 2-1 Syntax diagram

2.4 Physical Connection

Plug-in connectors on the operating device for connection to the controller.

2.4.1 Pin Assignment for Operating Devices with an Universal Interface

Table 2-12 Pin assignment TTY / 20 mA, active

Pin	Designation	Function
10	T+	Transmitted Data, Positive Polarity
12	S1+	Power Source 1, Positive Polarity
13	R+	Received Data, Positive Polarity
14	R-	Received Data, Negative Polarity
16	S2+	Power Source 2, Positive Polarity
19	T-	Transmitted Data, Negative Polarity
21	S1-	Current Sink 1, Negative Polarity
24	S2-	Current Sink 2, Negative Polarity

2.4.2 Cable SER1 TTY / 20 mA - Siemens S5 PU

The following cabling diagram applies to operating devices with an universal interface **only**.

Operating Device
Transmitter Active
Receiver Active

Siemens
Simatic S5
Transmitter Passive
Receiver Active

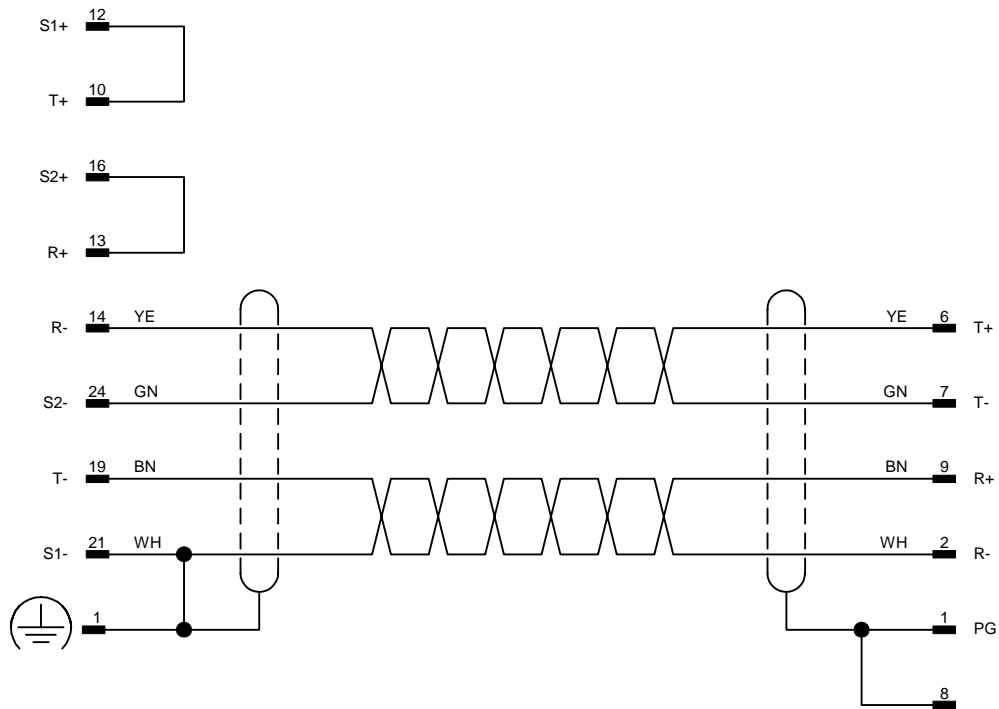

D-SUB
Male Connector
25 Pin

D-SUB
Male Connector
15 Pin

Both ends of the shield are connected to the metallic housing.

2.5 Error Messages

Error messages are displayed on the operating device along with a code and sub-code. Error messages are composed as follows:

Communication Error

Code XXXXX

Subcode XXXXX

Retries XXXXX

Table 2-13 Error messages for Siemens S5 PU (AS511)

Code	Subcode	Error Type	Possible Cause
1		Slave not ready	
2		Packets out of sequence	
3		Protocol frame error	
4		Waiting time elapsed (timeout)	Connection broken
6		Wrong parity	
7		Send process aborted	
8		Receive process aborted	
9		Cyclic buffer overrun	Cyclic buffer too small
10		No cyclic data defined	
12		Cyclic data already defined	
15		Protocol error	The selected protocol is not supported
16		Receive buffer overrun	
17		NAK from controller despite repetitions	
40		System variable error	Undefined system variable
Siemens-specific error messages			
50		Outside of range	Address outside of range of data block
	XXXX	The subcode contains the number of the data block	
51		Wrong number of data received	
52		Unknown function	
53		Wrong mode of operation	
54		Data block does not exist	
	XXXX	The subcode contains the number of the data block	
55		Communication has reached higher level	
56		Communication has reached lower level	

Table 2-13 Error messages for Siemens S5 PU (AS511)

Code	Subcode	Error Type	Possible Cause
57		Received invalid response from controller during connection setup phase	
	XXXX	The subcode contains the received character	
58		Received invalid response from controller during transmission phase	
	XXXX	The subcode contains the received character	
59		Received invalid response from controller during disconnect phase	
	XXXX	The subcode contains the received character	
60		CPU 921 detected	CPU 921 not supported
61		Wrong addressing	Only part of the requested address range is available

A Index

C

Cable SER1 TTY / 20 mA
Siemens S5 PU 2-9

E

Error messages
Siemens S5 PU (AS511) 2-10

I

Important notes 1-1
Intended use 1-1

O

Optimized data transmission for fast
screen set-up 2-3

P

Protocol parameters
Siemens S5 PU (AS511) 2-4

S

Safety notes 1-1
Siemens S5 PU (AS511) 2-1
Symbols 1-1
Syntax diagram
Siemens S5 PU (AS511) 2-7

T

Target group 1-1



